

COMPARISON OF FUZZY LOGIC CONTROLLER AND THE PROPORTIONAL INTEGRAL CONTROLLER FOR THE APPLICATION OF SMES TO IMPROVE THE POWER QUALITY DURING VOLTAGE SAG

¹Eldose valsalan, ²Haneesh K.M

¹PG Scholar, ²Asst. Prof.,

Dept. of Electrical and Electronics Engineering,

Christ University Faculty of Engineering, Bangalore,

Email: ¹eldosenilambur@gmail.com, ²Haneesh.km@christuniversity.in

Abstract—This paper presents a comparison between superconducting magnetic energy storage (SMES) with fuzzy logic controller (FLC) and SMES with proportional integral (PI) controller to improve the power quality during voltage sag events. Service interruptions cause financial losses to both utility and consumers. A superconducting magnet is selected as the energy storage unit because of its characteristic of high energy density and quick response to improve the compensation capability in Power system. The number of member function can be minimized and the time response of the controller becomes faster by using the fuzzy logic controller. This comparison is done in the point of view of power quality and it is shown that the system with fuzzy logic controller is highly reliable. Using MATLAB Simulink, the model of SMES with PI controller and model of SMES with fuzzy logic controller are established. Simulation results in both cases are compared and analyzed.

Keywords—SMES, Voltage Sag, Power Quality

I. INTRODUCTION

Electric load is increasing day by day. Hence the power transfer in the interconnected network also increased. This leads the power system to more complex and less secure. Power quality concern has a vital role in power system. The over use of power electronics leads to power quality problems. This will affect the sensitive loads. Power system engineers are seeking solutions to overcome this problem and to operate the system in more flexible, efficient and controllable manner. Energy storage devices can overcome this problem up to some extent. Energy storage devices like flywheel and super capacitor have less power rating and energy rating. So these devices can't use for higher power application. SMES have high power rating with maximum efficiency than any other storage devices. Recent developments and advances in both superconducting and power electronics technology have made the application of SMES systems a viable choice to solve some of the problems experienced in power systems.

II. SMES

An SMES unit is a device that stores energy in the magnetic field generated by the dc current flowing through a superconducting coil. An SMES system consists of a superconducting

coil, a power-conditioning system (PCS), a cryogenic refrigerator, and a cryostat/vacuum vessel to keep the coil at a low temperature required maintaining it in superconducting state [1]. Two types of PCS are commonly used. They are current source converter (CSC) and voltage source converter (VSC).

This configuration makes highly efficient in storing electricity in the range of 95%-98% [2]-[3]. Other advantages of the SMES unit include very quick response and possibilities for high-power applications [4]. A typical SMES configuration is shown in Fig.1.

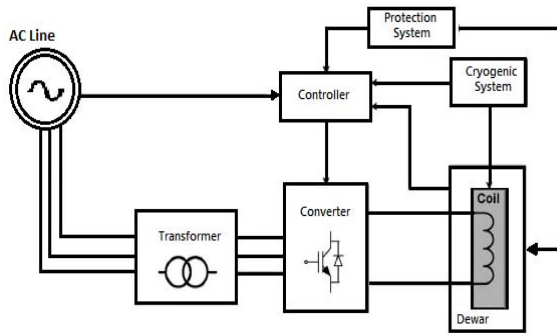

Fig. 1. Typical schematic diagram of an SMES unit.

III. CONTROL APPROACHES

There are two major configurations of SMES. They are CSC and VSC. Normally, CSC is connected through a 12-pulse converter configuration to eliminate the ac-side fifth and seventh harmonic currents and the dc-side sixth harmonic voltage, this result in savings in harmonic filters [5]. This configuration uses two 6-pulse CSCs that are connected in parallel which increase the cost. The VSC is connected with a dc-dc chopper through a dc link, which facilitates energy exchange between the SMES coil and the ac grid. Reference [6] estimates the total cost of the switching devices of the CSC to be 173% of the switching devices and power diodes required for equivalent capacity of the VSC and the chopper. VSC has a better self-commutating capability and the amount of harmonic current which can inject into the grid is lower

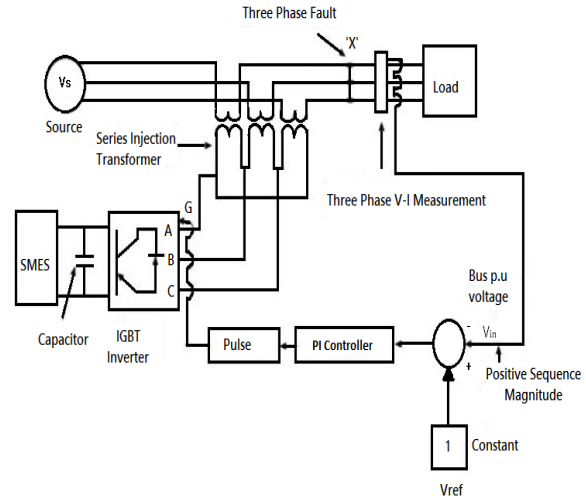

Fig. 2. SMES based DVR with PI controller

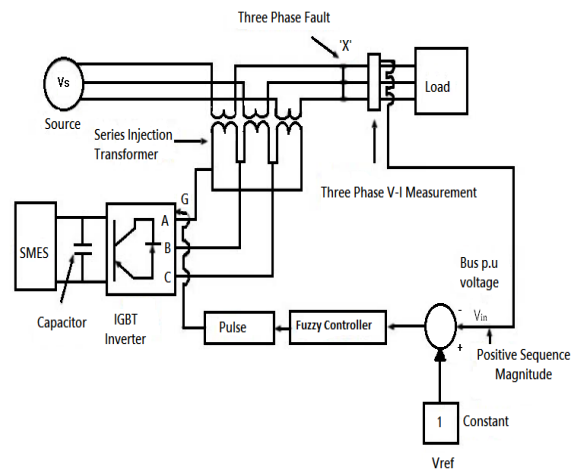

Fig. 3. SMES based DVR with fuzzy logic controller

than CSC. The switching frequency of an IGBT lies between the ranges of 2-20 KHz. But the switching frequency of GTO cannot exceed 1 KHz [7].

The SMES configuration used in this paper consists of a VSC and a dc-dc chopper. SMES with PI controller is shown in Fig.2. SMES with fuzzy logic controller is shown in Fig.3. The control strategy for pulse width modulation (PWM) converter can be divided into two, namely non-linear controller and linear controller. Fuzzy logic controller is non-linear controller. PI controller is linear controller.

Three phase fault is applied at load terminals at both cases as shown in Fig.2 and Fig.3. Load voltage is converted into per unit quantity. The magnitude is then compared with reference voltage (V_{ref}). The error signal thus produced is fed to PI controller. The PI controller processes the error signal and generates the required angle delta to drive the error to zero.

In Fig.3 fuzzy logic controller is used instead of PI controller, the remaining setup is same as that of PI controller.

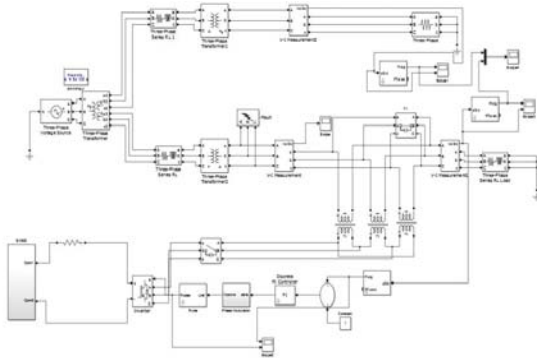

Fig.4. SIMULINK model of SMES with PI controller.

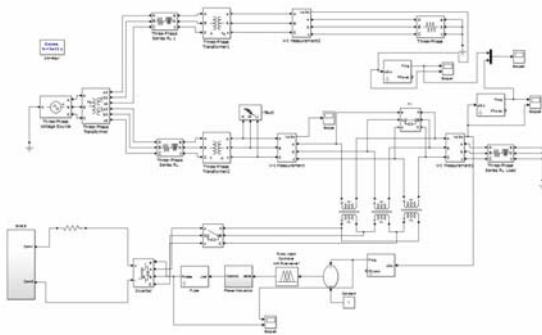

Fig.5. SIMULINK model of SMES with fuzzy logic controller

IV. SIMULATION RESULTS

To evaluate the performance of the SMES based DVR, a series of simulation is carried out with PI controller and FLC individually using MATLAB. Fig.4 shows the SIMULINK model of SMES based DVR with PI controller. Fig.5 shows the SIMULINK model of SMES based DVR with FLC.

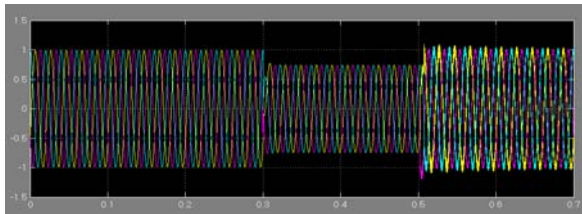

Fig.6. voltage under 3phase fault without SMES

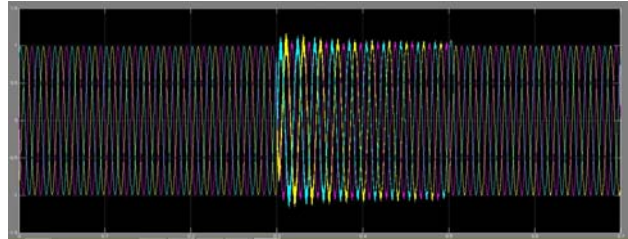

Fig.7. voltage under the action of SMES with PI controller

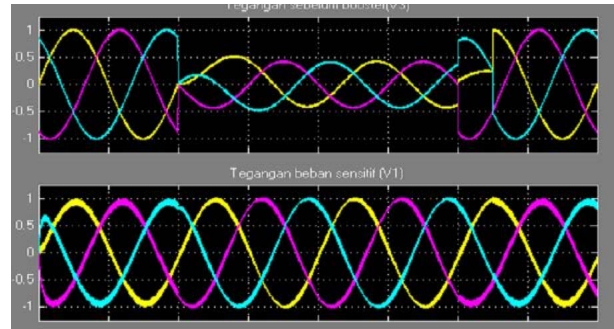

Fig 8. Three phase fault without and with the action of SMES with FLC controller..

During the simulation a three-phase voltage sag is simulated. The grid voltage drops to 50% of its nominal value and the DVR starts to operate. Fig.6 is the load voltage under fault. Fig.7 is the load voltage after compensation using PI controller. Fig.8 is the load voltage under fault and load voltage after compensation using FLC. From the obtained waveforms it is very clear that the DVR with FLC controller have better performance than the PI controller during the symmetrical fault.

V. CONCLUSION

This paper presents the SMES based DVR to compensate voltage fluctuations. It can compensate long term voltage fluctuation. Simulations results illustrate that the fuzzy logic controller has better performance than the PI controller.

VI. REFERENCES

- [1] P. F. Ribeiro, B. K. Johnson, M. L. Crow, A. Arsoy, and Y.Liu, "Energy storage systems for advanced power applications," *Proc.IEEE*, vol. 89, no. 12, pp. 1744-1756, Dec. 2001.
- [2] S. C.Smith, P. K. Sen, and B.Kroposki, "Advancement of energy storage devices and applications in electrical power system," in *proc.IEEE Power Energy Soc. Gen. Meeting-Convers. Del.Elect. Energy 21st Century*, 2008, pp. 1-8.

- [3] H.Chen, T. N. Cong, W. Yang, C. Tan, Y. Li, and Y. Ding, "Progress in electrical energy storage system: A critical review," *Progr. Natural sci.*, vol. 19, no. 3, pp. 291-312, Mar. 2009.
- [4] E. Ancha, V. G. Agelidis, O. Anaya-Lara, and T. J. E. Miller, *Power Electronic Control in Electrical Systems*, Oxford, U.K, Newnes,2002.
- [5] A. Abu-siada and S.Islam, "Application of SMES unit in improving the performance of an AC/DC power system," *IEEE Trans. Sustainable Energy*, vol. 2, no. 2, pp. 109-121, Apr.2011.
- [6] I.D. Hassan, R.M. Bucci, and K. T. Swe, "400 MW SMES power conditioning system development and simulation," *IEEE Trans. Power Electron.*, vol. 8, no. 3, pp. 237-249, Jul. 1993.
- [7] T.Ackerman, *Wind Power in Power System*. West Sussex, U.K, Wiley, 2005, p. 65.